

**GENERAL NOTES:**

- 1) MAXIMUM FLOW RATE 50 G.P.M. (230 l/min)
- 2) INFLUENT TEMP.: 40° F (5° C) & GREATER
- 3) INFLUENT OIL SPECIFIC GRAVITY: < 0.95
- 4) EFFLUENT QUALITY: < 0.0016 oz/gal. (< 10mg/l) TEH
- 5) RECOMMENDED OIL STORAGE: 200 imp. gal. (910L)
- 6) SLUDGE CAPACITY: 12.75 cu. ft. (0.36 cu. m)
- 7) COALESCING MEDIUM: A.F.C. TWIN CARTRIDGE COALESCING PACKAGE
- 8) PIPING: ø4" (100) PVC

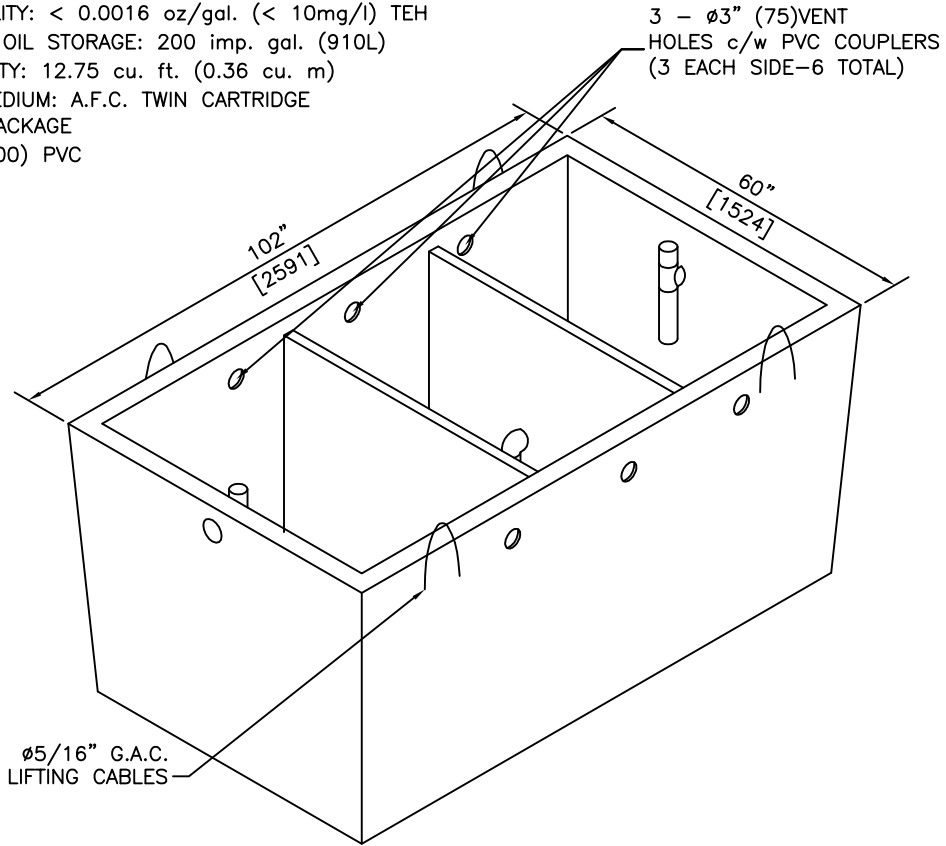

**ISOMETRIC**

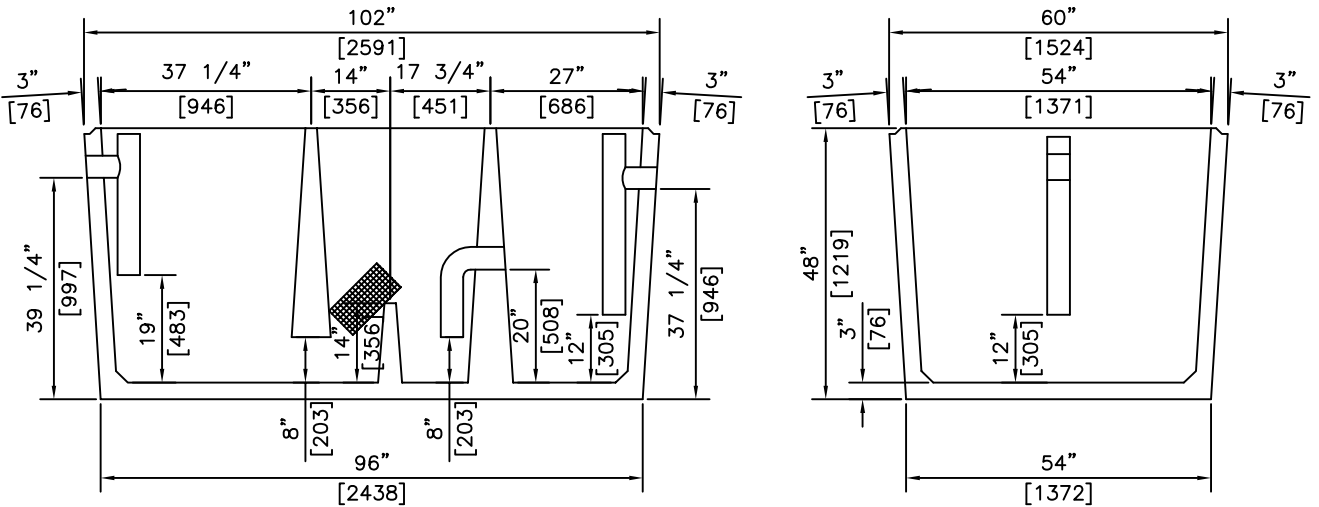

**SECTIONS**

**NOTES:**

US PATENT No 6,079,571  
 CANADIAN PATENT No 2,252,307

AFC OIL/WATER SEPARATOR SPECIFICATIONS ARE SUBJECT TO LIMITATIONS OF LIABILITY

REVISED: SEPT 25 2014

<b>A.F.C.</b> AMERICAN FORCECRETE OF CANADA Inc.	3891 Irvine Road LAKE COUNTRY, B.C. V4V 2G4 PH: (250) 548-0056 FX: (250) 765 0820	BY: PKR DATE: FEB 1 06 SCALE: NTS	<b>AFC OIL/WATER                  SEPARATOR - 50GPM                  (230L) H2O DESIGN</b>	ITEM NO. <b>1605</b>