

PLAN VIEW
TYPICAL / GENERIC
INSTALLATION

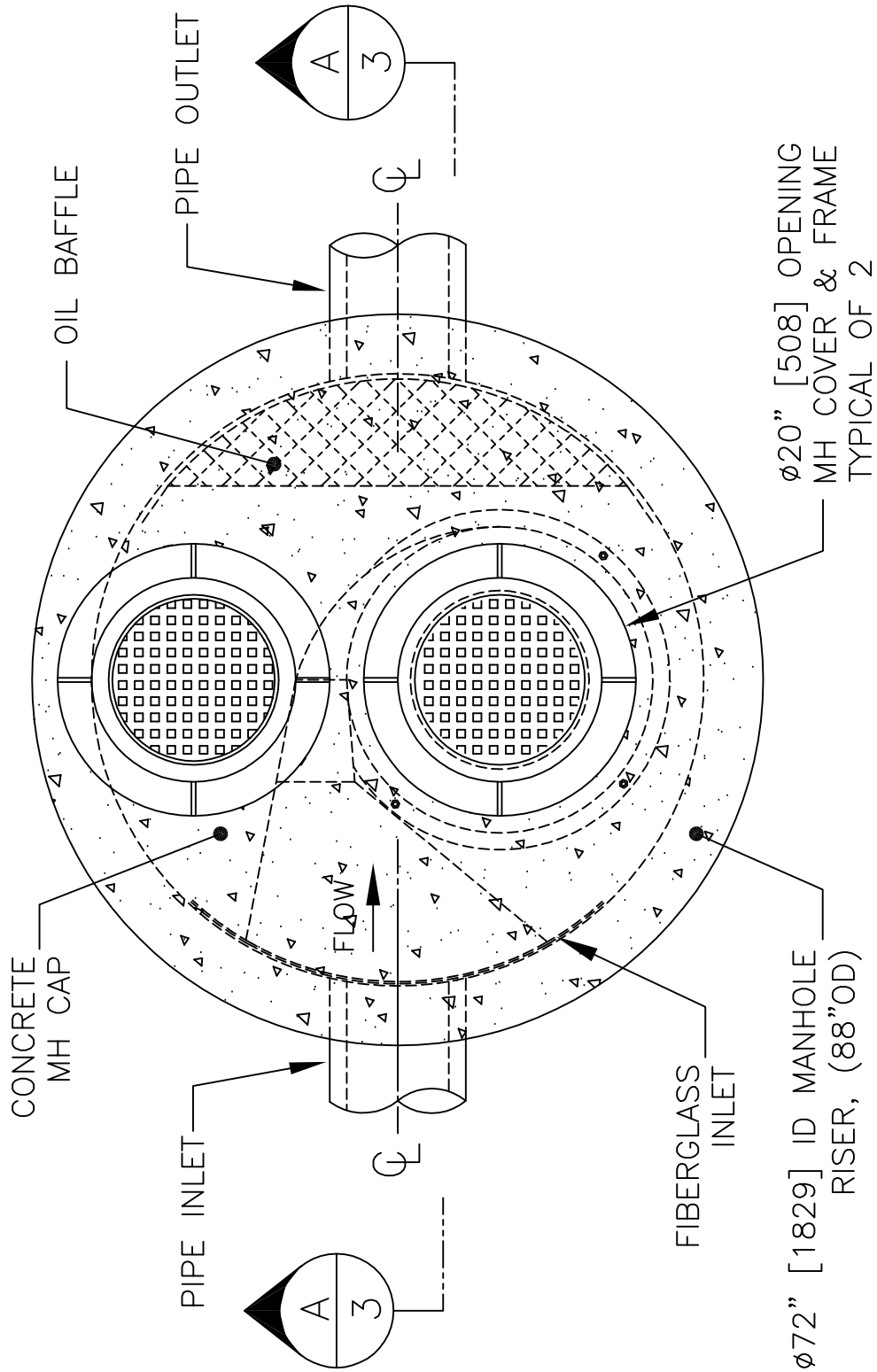

NOTE:
 THE INTERNAL COMPONENTS ARE SHOWN IN THE RIGHT-HAND
 CONFIGURATION—THESE COMPONENTS MAY BE FURNISHED IN THE
 MIRROR IMAGE TO THAT SHOWN (LEFT-HAND CONFIGURATION).

CDS MODEL PMSU30_30
 STORM WATER TREATMENT UNIT

ø72" [1829] ID MANHOLE
 RISER, (88"OD)

ø20" [508] OPENING
 MH COVER & FRAME
 TYPICAL OF 2



PROJECT NAME

JOB#	
DATE:	
DRAWN:	
APPROV.	

SCALE
 1" = 20"
 SHEET
1

SECTION B TYPICAL / GENERIC INSTALLATION

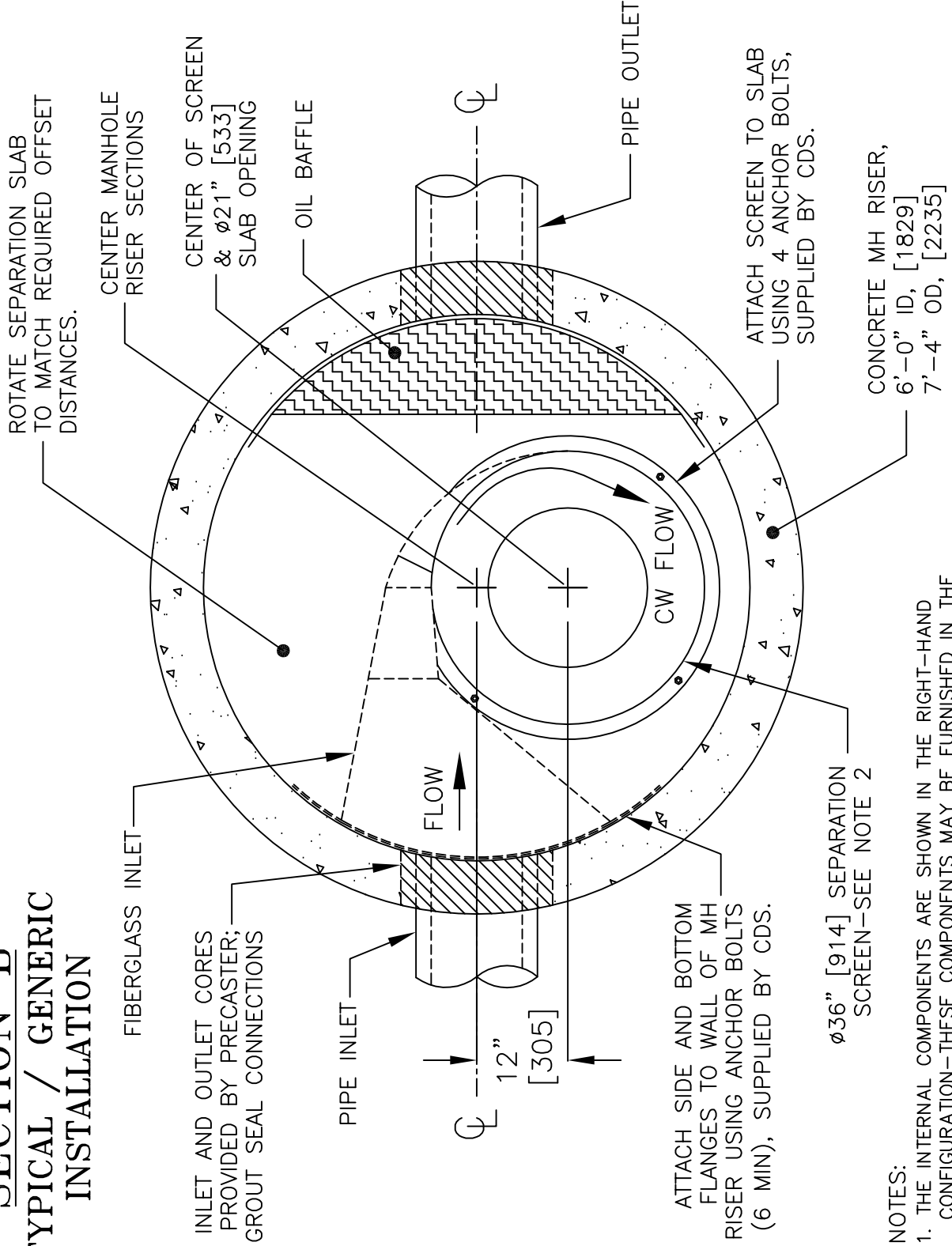

NOTES:

1. THE INTERNAL COMPONENTS ARE SHOWN IN THE RIGHT-HAND CONFIGURATION—THESE COMPONENTS MAY BE FURNISHED IN THE MIRROR IMAGE TO THAT SHOWN (LEFT-HAND CONFIGURATION).
2. CDS UNIT IS PRE-ASSEMBLED AND PARTIALLY DISASSEMBLED FOR SHIPPING; FOR PROPER INSTALLATION, GREEN FLANGE ON SCREEN FACES UP, RED FLANGE FASTENS TO SEPARATION SLAB.

CDS MODEL PMSU30_30
STORM WATER TREATMENT UNIT

	PROJECT NAME	JOB#	SCALE 1" = 20" SHEET 2
		DATE:	
		DRAWN:	
		APPROV.	

**SECTION A
ELEVATION VIEW**

**TYPICAL / GENERIC
INSTALLATION**

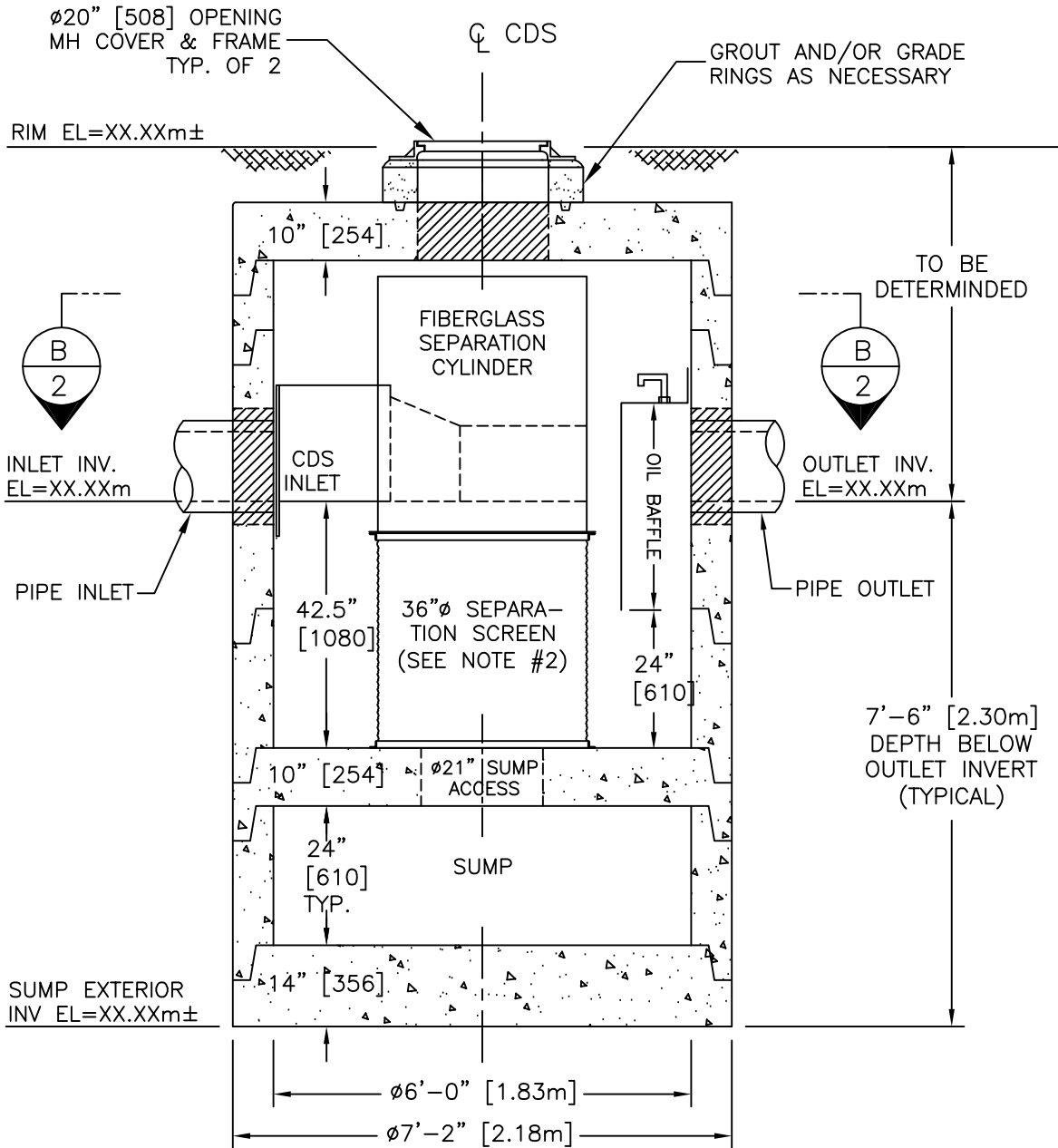

NOTES:

1. THE INTERNAL COMPONENTS ARE SHOWN IN THE RIGHT-HAND CONFIGURATION—THESE COMPONENTS MAY BE FURNISHED IN THE MIRROR IMAGE TO THAT SHOWN (LEFT-HAND CONFIGURATION).
2. FOR PROPER INSTALLATION, GREEN FLANGE ON SCREEN FACES UP FOR RIGHT-HAND INSTALLATIONS, RED FLANGE FACES UP FOR LEFT-HAND ORIENTED UNITS.

CDS MODEL PMSU30_30
STORMWATER TREATMENT UNIT



PROJECT NAME

JOB#	SCALE 1"=30" SHEET 3
DATE:	
DRAWN:	
APPROV.	

PLACE 2x CONTINUOUS BANDS OF MASTIC ROPE ON VERTICAL AND HORIZONTAL SURFACES OF SUMP (MH BASE) T&G JOINT; GROUT EXTERIOR MH JOINT IF NECESSARY.

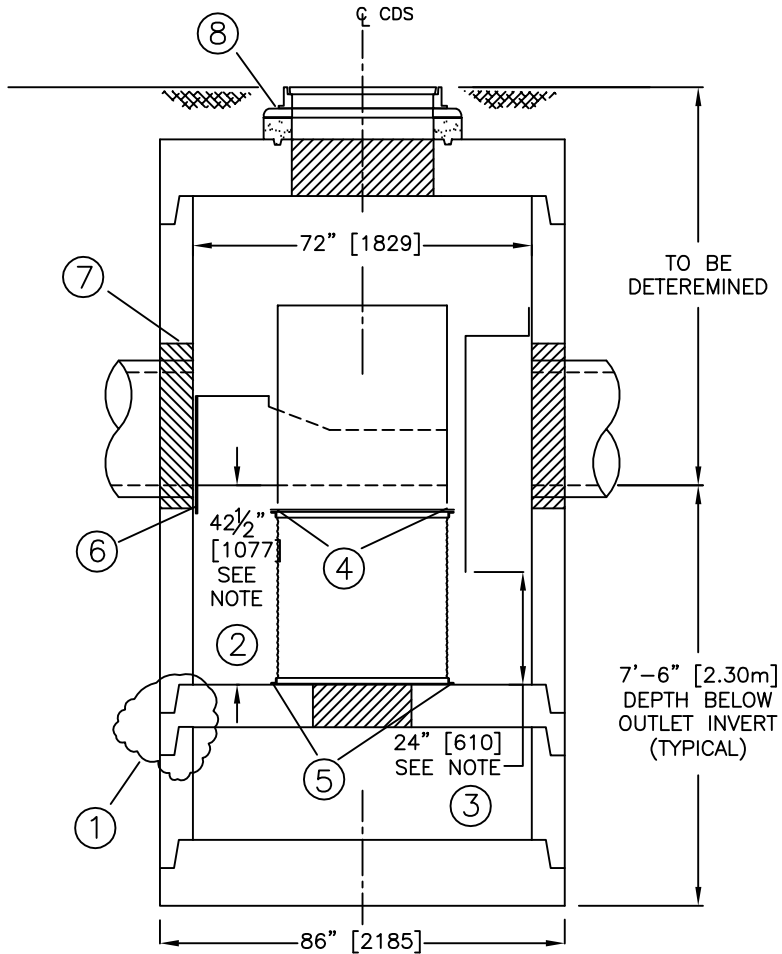
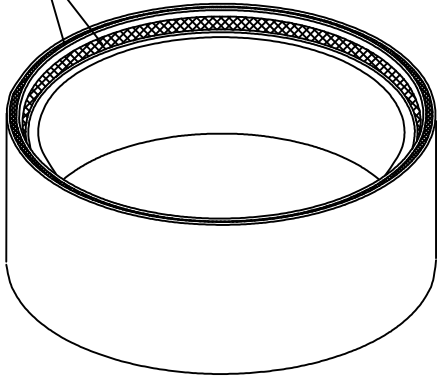

CONSTRUCTION NOTES:

1. APPLY BUTYL MASTIC AND/OR GROUT-SEAL EXTERIOR JOINT TO SEAL MANHOLE STRUCTURE UP TO FLOWLINE INVERT (MIN.)-APPLY LOAD TO MH SECTIONS TO COMPRESS SEALANT IF NECESSARY.
2. IF SEPARATION SLAB IS NON-INTEGRAL TO THE SEPARATION SECTION OF THE UNIT, SET AND VERIFY TOP ELEVATION BEFORE PLACING MORE PRECAST COMPONENTS OR BACKFILLING. ENSURE 42.5" [1080] FROM TOP OF SEPARATION SLAB TO PIPE INVERT.
3. SET BOTTOM OF OIL BAFFLE 24" [610] ABOVE SEPARATION SLAB FLOOR; DRILL AND INSERT A MINIMUM OF FOURTEEN (14) $\frac{3}{8}$ " x $3\frac{3}{4}$ " SS EXPANSION BOLTS @ 12" [305] O.C. EQUALLY SPACED TO SECURE BAFFLE FLANGE TO RISER WALL-(HARDWARE SUPPLIED BY CDS TECHNOLOGIES).
4. FASTEN FIBERGLASS CYLINDER/INLET TO SCREEN ASSEMBLY USING FOUR (4) SETS OF $\frac{3}{8}$ " x $1\frac{1}{2}$ " SS HEX HEAD BOLTS W/ NUTS AND WASHERS, EQUALLY SPACED; GREEN SCREEN FLANGE FACES UP FOR RIGHT HANDED UNITS; RED FLANGE FACES UP FOR LEFT HAND CONFIGURATIONS - (HARDWARE SUPPLIED BY CDS TECHNOLOGIES).
5. CENTER SEPARATION SCREEN WITH ATTACHED INLET ASSEMBLY OVER 21" [533] DIAMETER SUMP OPENING AND POSITION INLET FLANGE AGAINST MANHOLE WALL WITH INLET PIPE REASONABLY CENTERED WITHIN THE INLET ORIFICE; DRILL AND INSERT FOUR (4) $\frac{3}{8}$ " x $3\frac{3}{4}$ " SS EXPANSION BOLTS TO FASTEN SCREEN ASSEMBLY TO SEPARATION SLAB.
6. VERIFY THAT THE SEPARATION SCREEN IS CENTERED OVER SUMP OPENING AND ADJUST IF NECESSARY; DRILL & INSERT A MINIMUM OF SIX (6) $\frac{3}{8}$ " x $3\frac{3}{4}$ " SS EXPANSION BOLTS EQUALLY SPACED TO SECURE INLET FLANGE TO RISER WALL - (HARDWARE SUPPLIED BY CDS TECHNOLOGIES).
7. GROUT PIPE CONNECTIONS TO SEAL JOINT (TYPICAL).
8. BLOCK AND GROUT SEAL TO MATCH GRADE AS REQUIRED.

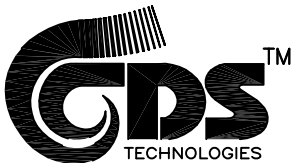

CDS MODEL PMSU30_30
MISCELLANEOUS NOTES

JOB#	SCALE N.T.S. SHEET 4
DATE:	
DRAWN:	
APPROV.	

PLACE 2x CONTINUOUS BANDS OF MASTIC ROPE ON VERTICAL AND HORIZONTAL SURFACES OF SUMP (MH BASE) T&G JOINT; GROUT EXTERIOR MH JOINT IF NECESSARY.

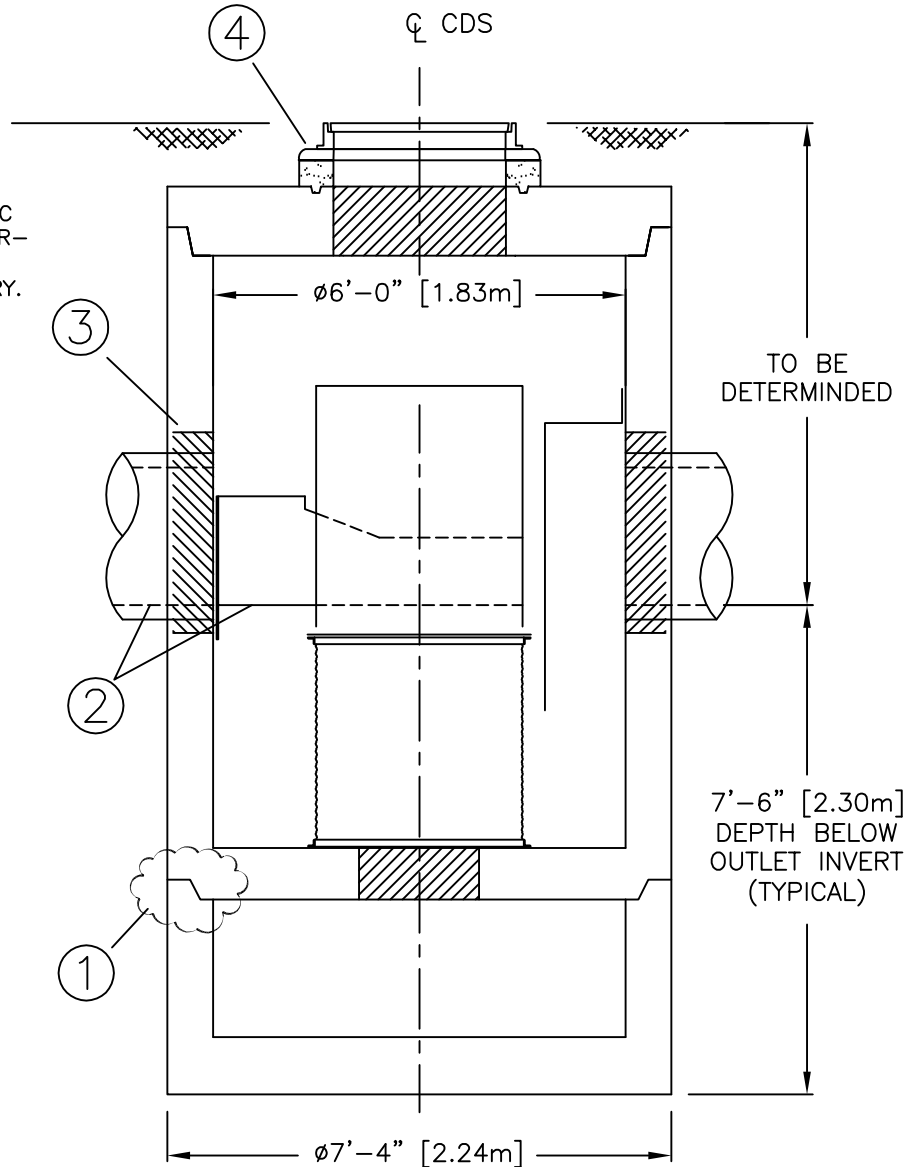
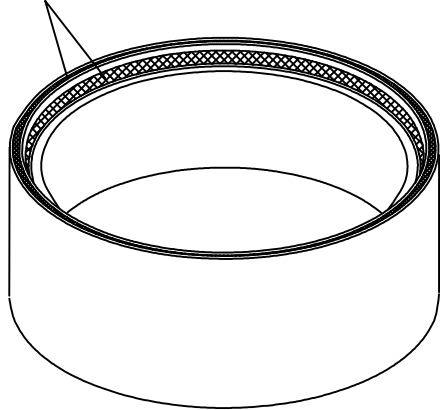

CONSTRUCTION NOTES:

1. APPLY BUTYL MASTIC TO SEAL JOINTS OF MANHOLE STRUCTURE (SEE INSET DETAIL DRAWING); APPLY GROUT TO EXTERIOR T&G JOINTS OF MH SECTIONS TO COMPLETELY SEAL IF NECESSARY (UNIT MUST BE WATER TIGHT, HOLDING WATER UP TO FLOWLINE INVERT, MINIMUM).
2. BEFORE PLACING MORE PRECAST COMPONENTS OR BACKFILLING, ENSURE FIBERGLASS INLET & (OUTLET) PIPE INLET INVERT ELEVATIONS MATCH – ADJUST IF NECESSARY.
3. PLACE GROUT OR USE FLEXIBLE CONNECTORS TO SEAL PIPE–MH CONNECTIONS.
4. USE GRADE RINGS AND/OR GROUT TO MEET FINISHED–GRADE ELEVATION; SEAL AS NECESSARY.

GENERAL NOTES:

1. CDS UNIT COMES COMPLETE WITH FIBERGLASS INLET, OIL BAFFLE AND SCREEN ASSEMBLY PRE–INSTALLED.
2. INSTALL UNIT PER CDS INSTALLATION GUIDELINES AND ALL APPLICABLE PROJECT SPECIFICATIONS.
3. CONTRACTOR TO BE EQUIPPED TO LIFT HEAVIEST PICK SECTION (APPROXIMATELY 7,300#).

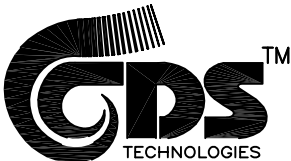
	CDS MODEL PMSU30_20 MISC. INSTALLATION NOTES	JOB#	SCALE N.T.S. SHEET 4
		DATE:	
		DRAWN:	
		APPROV.	